

# Factory-Made, Wrought Steel, Buttwelding Induction Bends for Transportation and Distribution Systems

---

AN AMERICAN NATIONAL STANDARD



The American Society of  
Mechanical Engineers

# **Factory-Made, Wrought Steel, Buttwelding Induction Bends for Transportation and Distribution Systems**

---

AN AMERICAN NATIONAL STANDARD



**The American Society of  
Mechanical Engineers**

Two Park Avenue • New York, NY • 10016 USA

Date of Issuance: December 29, 2017

The next edition of this Standard is scheduled for publication in 2022.

ASME issues written replies to inquiries concerning interpretations of technical aspects of this Standard. Periodically certain actions of the ASME B16 Committee may be published as Cases. Cases and interpretations are published on the ASME Web site under the Committee Pages at <http://cstools.asme.org/> as they are issued.

Errata to codes and standards may be posted on the ASME Web site under the Committee Pages to provide corrections to incorrectly published items, or to correct typographical or grammatical errors in codes and standards. Such errata shall be used on the date posted.

The Committee Pages can be found at <http://cstools.asme.org/>. There is an option available to automatically receive an e-mail notification when errata are posted to a particular code or standard. This option can be found on the appropriate Committee Page after selecting "Errata" in the "Publication Information" section.

ASME is the registered trademark of The American Society of Mechanical Engineers.

This code or standard was developed under procedures accredited as meeting the criteria for American National Standards. The Standards Committee that approved the code or standard was balanced to assure that individuals from competent and concerned interests have had an opportunity to participate. The proposed code or standard was made available for public review and comment that provides an opportunity for additional public input from industry, academia, regulatory agencies, and the public-at-large.

ASME does not "approve," "rate," or "endorse" any item, construction, proprietary device, or activity.

ASME does not take any position with respect to the validity of any patent rights asserted in connection with any items mentioned in this document, and does not undertake to insure anyone utilizing a standard against liability for infringement of any applicable letters patent, nor assume any such liability. Users of a code or standard are expressly advised that determination of the validity of any such patent rights, and the risk of infringement of such rights, is entirely their own responsibility.

Participation by federal agency representative(s) or person(s) affiliated with industry is not to be interpreted as government or industry endorsement of this code or standard.

ASME accepts responsibility for only those interpretations of this document issued in accordance with the established ASME procedures and policies, which precludes the issuance of interpretations by individuals.

No part of this document may be reproduced in any form,  
in an electronic retrieval system or otherwise,  
without the prior written permission of the publisher.

The American Society of Mechanical Engineers  
Two Park Avenue, New York, NY 10016-5990

Copyright © 2017 by  
THE AMERICAN SOCIETY OF MECHANICAL ENGINEERS  
All rights reserved  
Printed in U.S.A.



# CONTENTS

Foreword	iv	
Committee Roster	v	
Correspondence With the B16 Committee	vi	
Summary of Changes	viii	
List of Changes in Record Number Order	ix	
<b>1</b>	<b>Scope and Definitions</b>	<b>1</b>
<b>2</b>	<b>Pressure Ratings</b>	<b>2</b>
<b>3</b>	<b>Size</b>	<b>2</b>
<b>4</b>	<b>Marking</b>	<b>2</b>
<b>5</b>	<b>Material</b>	<b>3</b>
<b>6</b>	<b>Material for Bends Containing Welds</b>	<b>4</b>
<b>7</b>	<b>Chemical Composition</b>	<b>5</b>
<b>8</b>	<b>Material Properties</b>	<b>5</b>
<b>9</b>	<b>Heat Treatment</b>	<b>5</b>
<b>10</b>	<b>Qualification Bend</b>	<b>6</b>
<b>11</b>	<b>Test Requirements</b>	<b>7</b>
<b>12</b>	<b>Dimensional Requirements</b>	<b>8</b>
<b>13</b>	<b>Inspection of Production Bends</b>	<b>9</b>
<b>14</b>	<b>Certification</b>	<b>9</b>
<b>SR15</b>	<b>Supplementary Requirements</b>	<b>9</b>
<b>Mandatory Appendix</b>		
<b>I</b>	<b>References</b>	<b>12</b>
<b>Nonmandatory Appendices</b>		
<b>A</b>	<b>Quality System Program</b>	<b>13</b>
<b>B</b>	<b>Induction Bend Data Sheet</b>	<b>14</b>
<b>Figures</b>		
<b>1</b>	<b>Bend Dimensional Terms</b>	<b>3</b>
<b>2</b>	<b>Test Specimen Locations and Orientations — Longitudinal Seam</b>	<b>6</b>
<b>3</b>	<b>Test Specimen Locations and Orientations — Helical Seam</b>	<b>7</b>
<b>4</b>	<b>Measurement of Bend Angle and Out-of-Squareness</b>	<b>10</b>
<b>Tables</b>		
<b>1</b>	<b>Tensile Properties</b>	<b>4</b>
<b>2</b>	<b>Maximum Limits of Chemical Elements That May Be Used</b>	<b>4</b>
<b>3</b>	<b>Limits on Essential Variables</b>	<b>7</b>

## FOREWORD

In 1993, members of the ASME B31.8 Code for Pressure Piping, Gas Transmission and Distribution Piping Systems Committee approached the B16 Committee to develop a standard that covers pipeline bends produced by the induction bending process.

Subcommittee F reviewed the request and identified that no current specification covered this product to the satisfaction of the users. It was also determined that this Standard would need to be more performance-based than most other B16 standards, which are normally product standards with set dimensional requirements.

At the 1994 meeting of Subcommittee F, the project to develop a standard was accepted. Through the cooperation of producers and users familiar with the process, and with approval by the Standards Committee and ASME, ASME B16.49-2000 received approval as an American National Standard on April 25, 2000.

In 2005, the Committee undertook a general review of this document. Based on the usage of this Standard over the last 5 years, a number of revisions, clarifications, and additions were determined to be needed to make the document more user friendly. Some requirements were dropped, revised, and clarified to reflect the desires of the users and manufacturers. The reference data were updated and the interpretation section was removed from the Standard. These revisions were incorporated into the B16.49-2007 edition.

In 2012, the Committee reviewed this document and made revisions to requirements in hardness testing and updated the references found in [Mandatory Appendix I](#). ASME B16.49-2012 was approved by the American National Standards Institute (ANSI) on October 22, 2012.

In this 2017 Edition, provisions have been made to update verbiage and readings. Following the approval by the ASME B16 Standards Committee, approval as an American National Standard was given by ANSI on September 7, 2017, with the new designation ASME B16.49-2017.

# ASME B16 COMMITTEE

## Standardization of Valves, Flanges, Fittings, and Gaskets

(The following is the roster of the Committee at the time of approval of this Standard.)

### STANDARDS COMMITTEE OFFICERS

**R. Bojarczuk**, *Chair*  
**C. Davila**, *Vice Chair*  
**C. R. Ramcharran**, *Secretary*

### STANDARDS COMMITTEE PERSONNEL

<b>A. Appleton</b> , Alloy Stainless Products Co., Inc.	<b>R. C. Merrick</b> , Fluor Enterprises
<b>J. E. Barker</b> , Dezurik Water Controls	<b>M. Nayyar</b> , NICE
<b>K. Barron</b> , Ward Manufacturing	<b>W. H. Patrick</b> , The Dow Chemical Co.
<b>D. C. Bayreuther</b> , Metso Automation	<b>D. Raho</b> , Consultant
<b>W. Bedesem</b> , Consultant	<b>C. R. Ramcharran</b> , The American Society of Mechanical Engineers
<b>R. Bojarczuk</b> , ExxonMobil Research and Engineering Co.	<b>D. F. Reid</b> , VSP Technologies
<b>A. Cheta</b> , Qatar Shell GTL	<b>R. Schmidt</b> , Canadoll
<b>M. Clark</b> , NIBCO, Inc.	<b>J. Tucker</b> , Flowserve
<b>G. A. Cuccio</b> , Capitol Manufacturing Co.	<b>F. Volgstadt</b> , Volgstadt & Associates, Inc.
<b>J. D'Avanzo</b> , Fluoroseal Valves	<b>F. Feng</b> , <i>Delegate</i> , China Productivity Center for Machinery National Technical Committee
<b>C. Davila</b> , Crane Energy	<b>R. Barnes</b> , <i>Contributing Member</i> , Anric Enterprises, Inc.
<b>K. S. Felder</b> , Valero Energy	<b>P. V. Craig</b> , <i>Contributing Member</i> , Jomar Group
<b>D. Frikken</b> , Becht Engineering Co.	<b>B. G. Fabian</b> , <i>Contributing Member</i> , Pennsylvania Machine Works
<b>D. Hunt, Jr.</b> , Fastenal	<b>M. Katcher</b> , <i>Contributing Member</i> , Haynes International
<b>G. Jolly</b> , Samshin Ltd.	<b>A. G. Kireta, Jr.</b> , <i>Contributing Member</i> , Copper Development Association, Inc.
<b>E. J. Lain</b> , Exelon Nuclear	
<b>T. A. McMahon</b> , Emerson Process Management	

### SUBCOMMITTEE F — STEEL THREADED AND WELDING FITTINGS

<b>B. G. Fabian</b> , <i>Chair</i> , Pennsylvania Machine Works	<b>P. W. Heald</b> , Bonney Forge
<b>R. Schmidt</b> , <i>Vice Chair</i> , Canadoll	<b>D. Hunt, Jr.</b> , Fastenal
<b>E. Lawson</b> , <i>Secretary</i> , The American Society of Mechanical Engineers	<b>G. Jolly</b> , Samshin Ltd.
<b>J. Oh</b> , <i>Secretary</i> , The American Society of Mechanical Engineers	<b>F. Kavarana</b> , CBI, Inc.
<b>A. Appleton</b> , Alloy Stainless Products Co., Inc.	<b>W. Pritzl</b> , Erne Fittings GmbH
<b>G. A. Cuccio</b> , Capitol Manufacturing Co.	<b>J. Tucker</b> , Flowserve
<b>J. G. Dominguez</b> , Welding Outlets, Inc.	<b>G. T. Walden</b> , Walseley
<b>K. W. Doughty</b> , CB&I Alloy Piping Products	<b>M. M. Zaidi</b> , Jacobs Engineering
<b>J. P. Ellenberger</b>	<b>C. J. Lafferty</b> , <i>Alternate</i> , U.S. Drop Forge Co.
<b>D. Frikken</b> , Becht Engineering Co.	

## CORRESPONDENCE WITH THE B16 COMMITTEE

**General.** ASME Standards are developed and maintained with the intent to represent the consensus of concerned interests. As such, users of this Standard may interact with the Committee by requesting interpretations, proposing revisions or a case, and attending Committee meetings. Correspondence should be addressed to:

Secretary, B16 Standards Committee  
The American Society of Mechanical Engineers  
Two Park Avenue  
New York, NY 10016-5990  
<http://go.asme.org/Inquiry>

**Proposing Revisions.** Revisions are made periodically to the Standard to incorporate changes that appear necessary or desirable, as demonstrated by the experience gained from the application of the Standard. Approved revisions will be published periodically.

The Committee welcomes proposals for revisions to this Standard. Such proposals should be as specific as possible, citing the paragraph number(s), the proposed wording, and a detailed description of the reasons for the proposal, including any pertinent documentation.

**Proposing a Case.** Cases may be issued to provide alternative rules when justified, to permit early implementation of an approved revision when the need is urgent, or to provide rules not covered by existing provisions. Cases are effective immediately upon ASME approval and shall be posted on the ASME Committee Web page.

Requests for Cases shall provide a Statement of Need and Background Information. The request should identify the Standard and the paragraph, figure, or table number(s), and be written as a Question and Reply in the same format as existing Cases. Requests for Cases should also indicate the applicable edition(s) of the Standard to which the proposed Case applies.

**Interpretations.** Upon request, the B16 Standards Committee will render an interpretation of any requirement of the Standard. Interpretations can only be rendered in response to a written request sent to the Secretary of the B16 Standards Committee.

Requests for interpretation should preferably be submitted through the online Interpretation Submittal Form. The form is accessible at <http://go.asme.org/InterpretationRequest>. Upon submittal of the form, the Inquirer will receive an automatic e-mail confirming receipt.

If the Inquirer is unable to use the online form, he/she may e-mail the request to the Secretary of the B16 Standards Committee at [SecretaryB16@asme.org](mailto:SecretaryB16@asme.org), or mail it to the above address. The request for an interpretation should be clear and unambiguous. It is further recommended that the Inquirer submit his/her request in the following format:

Subject:	Cite the applicable paragraph number(s) and the topic of the inquiry in one or two words.
Edition:	Cite the applicable edition of the Standard for which the interpretation is being requested.
Question:	Phrase the question as a request for an interpretation of a specific requirement suitable for general understanding and use, not as a request for an approval of a proprietary design or situation. Please provide a condensed and precise question, composed in such a way that a "yes" or "no" reply is acceptable.
Proposed Reply(ies):	Provide a proposed reply(ies) in the form of "Yes" or "No," with explanation as needed. If entering replies to more than one question, please number the questions and replies.
Background Information:	Provide the Committee with any background information that will assist the Committee in understanding the inquiry. The Inquirer may also include any plans or drawings that are necessary to explain the question; however, they should not contain proprietary names or information.

Requests that are not in the format described above may be rewritten in the appropriate format by the Committee prior to being answered, which may inadvertently change the intent of the original request.



Moreover, ASME does not act as a consultant for specific engineering problems or for the general application or understanding of the Standard requirements. If, based on the inquiry information submitted, it is the opinion of the Committee that the inquirer should seek assistance, the inquiry will be returned with the recommendation that such assistance be obtained.

ASME procedures provide for reconsideration of any interpretation when or if additional information that might affect an interpretation is available. Further, persons aggrieved by an interpretation may appeal to the cognizant ASME Committee or Subcommittee. ASME does not "approve," "certify," "rate," or "endorse" any item, construction, proprietary device, or activity.

**Attending Committee Meetings.** The B16 Standards Committee regularly holds meetings and/or telephone conferences that are open to the public. Persons wishing to attend any meeting and/or telephone conference should contact the Secretary of the B16 Standards Committee.

## ~~ASME B16.49-2017~~ SUMMARY OF CHANGES

Following approval by the ASME B16 Committee and ASME, and after public review, ASME B16.49-2017 was approved by the American National Standards Institute on September 7, 2017.

ASME B16.49-2017 includes the following changes identified by a margin note, **(17)**. The Record Numbers listed below are explained in more detail in the "List of Changes in Record Number Order" following this Summary of Changes.

<i>Page</i>	<i>Location</i>	<i>Change (Record Number)</i>
9	13.1	Second and last sentences revised (12-393)
12	Mandatory Appendix I	References updated (16-803)

## LIST OF CHANGES IN RECORD NUMBER ORDER

<u>Record Number</u>	<u>Change</u>
12-393	Revised para. 13.1 to define limits of upset in B16.49 induction bends.
16-803	Updated References.

## **FOREWORD**

INTENTIONALLY LEFT BLANK

# FACTORY-MADE, WROUGHT STEEL, BUTTWELDING INDUCTION BENDS FOR TRANSPORTATION AND DISTRIBUTION SYSTEMS

## 1 SCOPE AND DEFINITIONS

### 1.1 General

This Standard covers design, material, manufacturing, testing, marking, and inspection requirements for factory-made pipeline bends of carbon steel materials having controlled chemistry and mechanical properties, produced by the induction bending process, with or without tangents. This Standard covers induction bends for transportation and distribution piping applications (e.g., ASME B31.4 and ASME B31.8). Process and power piping have differing requirements and materials that may not be appropriate for the restrictions and examinations described herein and, therefore, are not included in this Standard.

### 1.2 Manufacturing Process

This process utilizes induction heating to heat a narrow band 360 deg around a pipe or cylinder at the point of bending as the pipe or cylinder is being pushed through the inductor coil at a constant velocity. After the material passes through the coil, it may be cooled by forced air or water spray, or it may be allowed to cool in still air. Bends in any producible wall thickness and diameter are covered. Induction bends covered by this Standard may be produced from seamless pipe, welded pipe, or cylinders.

### 1.3 Fabricated Bends

Larger angle bends obtained by girth welding two or more smaller angle bends together are considered pipe fabrications and as such, are not within the scope of this Standard.

### 1.4 Standard Units

This Standard states values in both SI (Metric) and U.S. Customary units. These systems of units are to be regarded separately as standard. Within the text, the U.S. Customary units are shown in parentheses. The values stated in each system are not exact equivalents; therefore, it is required that each system of units be used independently of the other. Combining values from the two systems constitutes nonconformance with the Standard.

### 1.5 References

Standards and specifications adopted by reference in this Standard are shown in [Mandatory Appendix I](#). It is not practical to identify the specific edition of each standard and specification in the individual references. Instead, the specific edition reference is identified in [Mandatory Appendix I](#). A product made in conformance with a prior edition of reference standards and in all other respects conforming to this Standard will be considered to be in compliance.

### 1.6 Codes and Regulations

A bend used under the jurisdiction of a referencing code or governmental regulation is subject to any limitation of that code or regulation. This includes any maximum temperature limitation or rule governing the use of a material at low temperature.

### 1.7 Service Conditions

Criteria for selection of bend material for a particular fluid service are not within the scope of this Standard.

### 1.8 Convention

For determining conformance with this Standard, the convention for fixing significant digits where limits (maximum and minimum values) are specified shall be as defined in ASTM E29. This requires that an observed or calculated value be rounded off to the nearest unit in the last right-hand digit used for expressing the limit. Decimal values and tolerances do not imply a particular method of measurement.

### 1.9 Quality Systems

Requirements relating to the manufacturers' quality system programs are described in [Nonmandatory Appendix A](#).

### 1.10 Glossary

*bend qualification procedure*: a document that specifies the properties of the starting pipe; the equipment to be used; the bending parameters; the qualification bend test results; and the postbend, heat-treat equipment, and cycle used for the manufacture of the bends. If nondestructive testing of the bend is required, procedures that have not been approved previously shall be submitted.

## ASME B16.49-2017

*cylinder*: a joint of pipe produced by a rolling and welding plate, as opposed to a joint of pipe produced in accordance with a recognized specification.

*extrados*: the outside arc of the bend.

*intrados*: the inside arc of the bend.

*minimum (design) wall thickness*: the wall thickness specified or computed in accordance with the piping code as the minimum acceptable for the temperature and pressure application.

*nominal (design) wall thickness*: the wall thickness specified on the order or marked on the bend.

*ovality, %*:  $[(O.D. \text{ max.} - O.D. \text{ min.}) / (O.D. \text{ nom.})] \times 100$ , where O.D. is a linear measurement of the maximum, minimum, or nominal outside diameter.

*qualification bend*: a bend segment that is produced and tested, and is used to qualify the bending procedure.

*transition zone*: the area, at the tangent points of a bend, that covers the change (transition) from unheated to heated material.

NOTE: The terms *bender* and *manufacturer* are used interchangeably in this Standard.

### 1.11 Ordering Information

The purchaser shall be responsible to specify all the ordering information necessary to purchase the needed bends. Examples of such information include, but are not limited to, the following:

- (a) quantity
- (b) description of bend and nominal dimensions (i.e., size, bend radius, wall thickness, bend angle, tangent lengths, etc.)
- (c) steel composition by grade
- (d) seamless or welded
- (e) specification number (including year)
- (f) supplementary requirements from section SR15
- (g) additional requirements

Nonmandatory Appendix B is provided as one possible guideline for providing the required information.

## 2 PRESSURE RATINGS

### 2.1 Basis of Ratings

The allowable internal pressure rating for bends designed in accordance with this Standard shall not be less than that which is calculated for straight seamless pipe (or for pipe welded with a joint efficiency factor of 1.0) of equivalent material (as shown by comparison of composition and mechanical properties in the respective material specifications) in accordance with the rules established in the applicable sections of the referencing code for pressure piping. For these calculations, applicable data for the nominal size, nominal wall thickness, and

material equivalent to that of the bend material shall be used. Nominal size, nominal wall thickness, and material identity markings on the bend may be used in lieu of pressure-rating markings.

### 2.2 Design of Bends

The required internal pressure design thickness at the intrados (inside radius) of the bend shall be determined in accordance with eq. (1) of this Standard. The thickness at the neutral axis (see Figure 1) and on the extrados (outer radius) of the bend shall be no less than the mating pipe design thickness or the customer-specified minimum wall thickness.

$$T_i \geq \frac{4(R/D_o) - 1}{4(R/D_o) + 2} t \quad (1)$$

where

$D_o$  = nominal outside diameter

$R$  = bend centerline radius

$T_i$  = minimum required thickness at the intrados

$t$  = nominal design wall thickness (see para. 2.1)

## 3 SIZE

The diameter of bends shall be identified by the nominal pipe size (NPS) as defined in ASME B36.10M (e.g., NPS 24). Alternatively or in addition, the marking may include the nominal size as defined in ISO 6708, which consists of the letters "DN" followed by a dimensionless whole number, which is indirectly related to the physical size, in millimeters, of the outside diameter of pipe to which the bend is intended to be welded (e.g., DN 600).

## 4 MARKING

### 4.1 Standard Marking

Each bend shall be marked on the outside surface within 300 mm (12 in.) of one end to show the following:

- (a) manufacturer's name or trademark
- (b) heat number or manufacturer's heat identification
- (c) material grade symbol (see para. 11.3 and Table 1)
- (d) B16.49
- (e) nominal pipe size (NPS)
- (f) nominal wall thickness
- (g) bend radius
- (h) bend angle
- (i) postbending, heat-treatment condition (see para. 9.3)
- (j) supplementary requirements (if applicable) (see section SR15)

Marking may be in any consistent units (metric or customary) but care shall be taken to avoid confusion. Use "X" and grade in lieu of "P" and grade for material designation for the customary stamping option.

ASME B16.49-2017

Figure 1 Bend Dimensional Terms

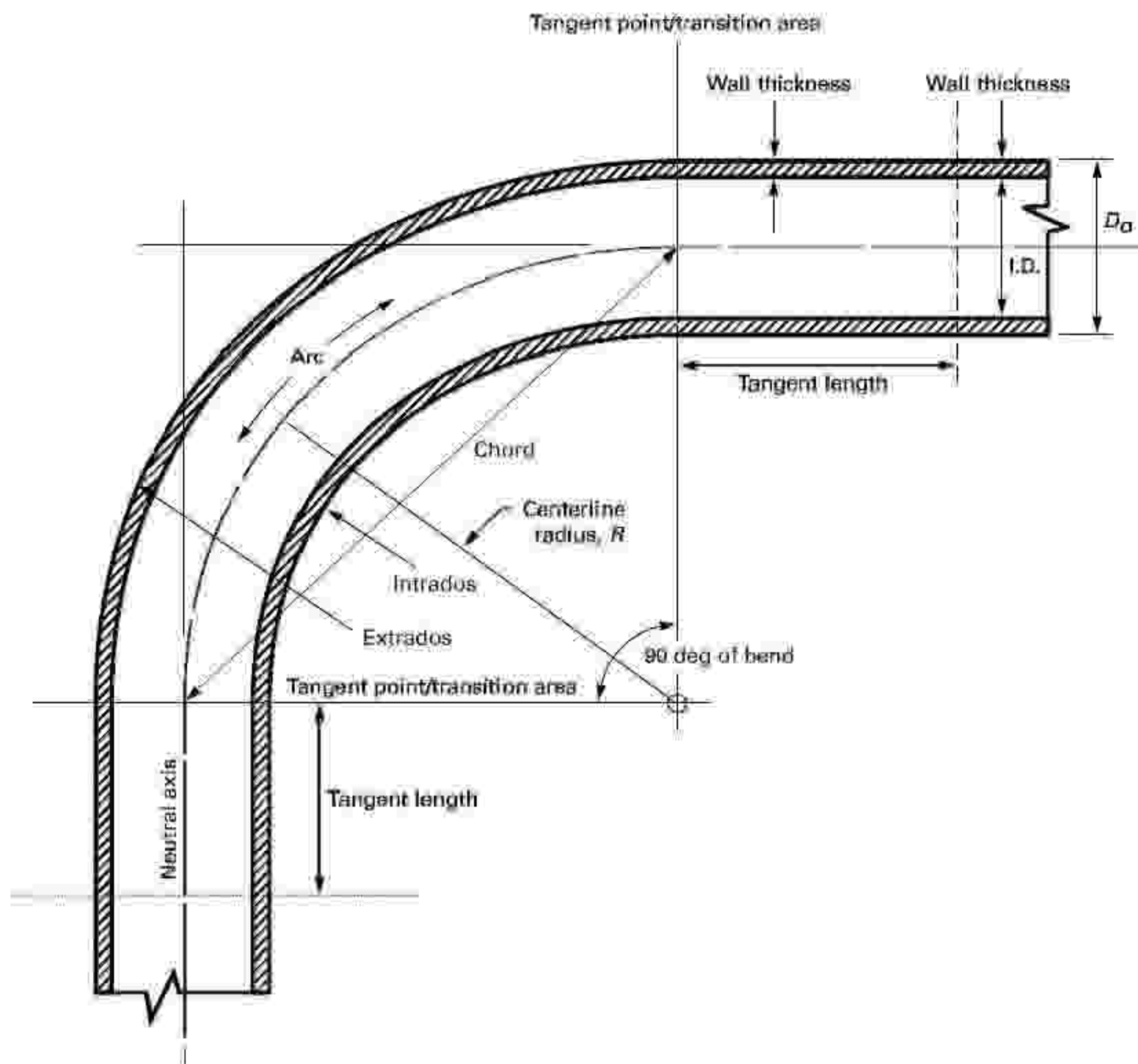

When specified by the purchaser, each bend shall be paint-stenciled with the same information in 25 mm (1 in.) or larger letters on the inside surface within 150 mm (6 in.) of each end, except for NPS 12 (DN 300) or smaller, which only requires outside surface marking. Marking materials shall not adversely affect the bend or coating.

#### 4.2 Depth of Stamping

Where steel stamps are used, care shall be taken so that the stamping is not so deep or so sharp as to cause cracking, or to reduce the wall thickness of the bend below the minimum allowed.

#### 4.3 Compliance

Marking B16.49 on the bend designates that the bend was manufactured in conformance with ASME B16.49. Adding the prefix "ASME" is optional.

## 5 MATERIAL

### 5.1 Starting Materials

Bends covered by this Standard shall be produced from carbon steel pipe or cylinders having a chemistry in conformance with Table 2. Pipe may be furnished by the purchaser or supplied by the manufacturer. Starting pipe shall be seamless, submerged arc welded (SAW), or electric resistance welded. Helically welded pipe is allowed, provided the more stringent testing requirements of para. 11.1.3(b) are met. Starting material shall be free from low-melting temperature metals, cracks, nicks, gouges, waves, buckles, or other such surface contamination defects that may inhibit successful completion of a bend.

**5.1.1 Contamination.** Contamination of pipe surfaces before or during bending by low-melting temperature metals (i.e., copper, brass, zinc/galvanized, aluminum,

## ASME B16.49-2017

Table 1 Tensile Properties

Grade (Symbol)	Minimum Tensile Properties			Maximum Hardness	
	Yield Strength, MPa (ksi)	Tensile Strength, MPa (ksi)	Elongation, %	HBW [Note (1)]	HRC [Note (2)]
P241 (X241)	241 (35)	414 (60)	20	238	22
P290 (X290)	290 (42)	414 (60)	20	238	22
P317 (X317)	317 (46)	434 (63)	20	238	22
P359 (X359)	359 (52)	455 (66)	20	238	22
P386 (X386)	386 (56)	490 (71)	20	238	22
P414 (X414)	414 (60)	517 (75)	20	238	22
P448 (X448)	448 (65)	531 (77)	18	238	22
P483 (X483)	483 (70)	565 (82)	16	247	24
P552 (X552)	552 (80)	621 (90)	16	247	24

GENERAL NOTE: Intermediate grades may be purchased subject to agreement between the purchaser and manufacturer.

## NOTES:

(1) HBW (Hardness Brinell) is the primary number.

(2) HRC (Hardness Rockwell C) is an approximation based on ASTM E140 hardness conversion.

Table 2 Maximum Limits of Chemical Elements That May Be Used

Element	Symbol	Maximum, %
Carbon	C	0.30
Manganese	Mn	1.60 [Note (1)]
Phosphorus	P	0.025
Sulfur	S	0.015
Silicon	Si	0.50
Chromium	Cr	0.30
Molybdenum	Mo	0.25
Vanadium	V	0.10
Copper	Cu	0.50
Nickel	Ni	1.00
Niobium	Nb (Cb)	0.10

GENERAL NOTE: The chemical requirements of this Table are not intended to represent the composition of any heat of steel, but to record the maximum permissible amounts of individual elements.

NOTE: (1) For Grades P483 (X483) and higher, for each reduction of 0.01% below the specified maximum carbon content, an increase of 0.05% above the maximum manganese content is permissible, up to a maximum of 2.00%.

etc.) can have serious effects on the bending process and the finished bend properties. Contact with such metals shall not be allowed.

**5.1.2 Surface Condition.** Prior to bending, material Grades P359 (X359) and higher shall be grit-blasted to a commercial finish (SSPC-SP 6) as a minimum on those sections to be bent.

## 6 MATERIAL FOR BENDS CONTAINING WELDS

## 6.1 Longitudinal Weld Seams

**6.1.1** Seam welds in pipe made to an API, ASTM, or CSA specification must meet welding and nondestructive examination (NDE) requirements of that specification.

**6.1.2** Other pipe or cylinders, not manufactured to the above specifications, shall be made by welders, welding operators, and welding procedures qualified under the provisions of Section IX of the ASME Boiler and Pressure Vessel Code (BPVC). Before bending, 100% of each weld seam shall be radiographed in accordance with ASME Section VIII, Division 1, para. UW-51, and shall meet the acceptance criteria specified therein.

In place of radiographic examination, welds may be ultrasonically examined in accordance with Appendix 12 of ASME Section VIII, Division 1.

**6.1.3** The longitudinal weld seam should be located on the neutral axis ( $\phi = 0$  deg or 180 deg in Figure 1). When this is not possible, the weld seam shall be located not more than 15 deg from the neutral axis. Helically welded pipe is an exception to this weld location requirement.

## 6.2 Girth Welds

Bending through a girth weld shall not be allowed unless agreed upon between the purchaser and manufacturer.



## 7 CHEMICAL COMPOSITION

The chemical composition of each heat<sup>1</sup> of material furnished to this Standard, as determined by a product analysis, shall be in accordance with Table 2. Each element specified in Table 2 shall be tested for and reported on the material test report required in section 14. The carbon equivalent (CE) shall not exceed 0.45% as computed by eq. (2):

$$CE = C + \frac{Mn}{6} + \frac{(Cr + Mo + V)}{5} + \frac{(Cu + Ni)}{15} \quad (2)$$

## 8 MATERIAL PROPERTIES

The properties of the bend, as determined for each lot,<sup>2</sup> shall be in accordance with the ordered grade listed in Table 1.

### 8.1 Tensile Properties

The tensile properties shall be determined for the qualification bend in accordance with ASTM A370. The yield-to-tensile ratio shall not exceed 0.90, except for Grade P483 (X483) and higher, for which the ratio shall not exceed 0.93. When the strength of the bend does not meet the ordered strength, the manufacturer may provide, with purchaser approval, bends of comparable strength to the design pipe. The thickness of the bend shall be at least equal to the specified design pipe thickness multiplied by the ratio of the specified minimum yield strength of the pipe and the minimum tested yield strength of the bend. For bends from welded pipe of NPS 8 (DN 200) or larger, a transverse weld tensile test in the final heat-treat condition shall be conducted to determine the ultimate tensile strength. See para. 11.1.1 for number, location, and orientation of test samples required.

### 8.2 Fracture Toughness Properties

Notch toughness properties of the bend material in the final heat-treated condition shall be determined on the qualification bend in all locations specified in Figure 2 or Figure 3 by a set of three transverse, full-size, Charpy V-notch specimens, with or without tapering<sup>3</sup> the ends, in accordance with ASTM A370. When the material wall thickness does not permit machining full-size (10 mm × 10 mm) specimens, the largest size possible of either ½ size or ¼ size shall be substituted. All dimensions other than thickness are the same for full-size specimens. Specimens shall be taken with the axis transverse to

the longitudinal axis of the bend. If material wall thickness does not allow at least a ½-size Charpy specimen, no impact testing is required. Specimens shall be tested at -10°C (+14°F) or lower, unless otherwise specified by the purchaser (see para. SR15.4), and shall achieve an average shear area for all specimens of at least 50%, with no one specimen less than 40%. In addition, all specimens shall exhibit a minimum absorbed energy value of 27 J (20 ft-lbf) for Grade P386 (X386) and lower, and a minimum of 54 J (40 ft-lbf) for grades higher than P386 (X386). Weld metal shall meet an absorbed energy value of 27 J (20 ft-lbf) minimum for all grades.

If using reduced specimens, the impact values may be reduced in accordance with the correction ratios in ASTM A370. See para. 11.1.2 for location of testing samples required.

### 8.3 Hardness Testing

Hardness tests shall be performed in accordance with ASTM A370 on the bend as required in para. 11.1.4. To verify uniformity in the bending process, all production bends shall be tested for hardness in the same locations as the qualification bend. The corresponding areas shall have average hardness readings not varying by more than 30 Brinell hardness, or equivalent, from the average value measured in the same location of the qualification bend, with no average equating to a tensile strength less than that required in Table 1 for the material grade marked on the bend. Use an average of at least three readings for each location tested. The type of portable hardness tester used on production bends shall be the same as used on the qualification bend. All testing shall be conducted in the final heat-treated condition. No hardness measurement shall exceed the maximum specified in Table 1.

## 9 HEAT TREATMENT

### 9.1 Type

Unless otherwise specified by the purchaser, each bend shall be heat-treated after bending (except as permitted in para. SR15.1) by one or more of the following methods:

(a) *Stress Relieve or Temper.* Uniformly, heat between 480°C (900°F) and 675°C (1,250°F) and hold at temperature for at least 30 min per 25 mm (1 in.) of thickness at temperature, but no less than 30 min.

(b) *Normalize.* Heat above the transformation temperature range and hold at temperature for a minimum of 20 min per 25 mm (1 in.) of thickness, but not less than 20 min, and allow to cool in still air.

(c) *Quench and Temper.* Heat above the transformation temperature range and hold at temperature for a minimum of 20 min per 25 mm (1 in.) of thickness and direct quench in either water, oil, or a synthetic quenchant. Reheat to temper as defined above. Quench

<sup>1</sup> A heat of material shall consist of all pipe or cylinders from the same manufacturer and produced from a single cycle of a batch melting process.

<sup>2</sup> A lot shall consist of all bends from the same heat of material given the same heat treatment in a controlled furnace within a range of ±15°C (±25°F).

<sup>3</sup> When tapered end specimens are used, the tapering shall not reduce the specimen length on one side below 28 mm (1.1 in.) or the end thickness below one-half the nominal specimen thickness.

Figure 2 Test Specimen Locations and Orientations — Longitudinal Seam

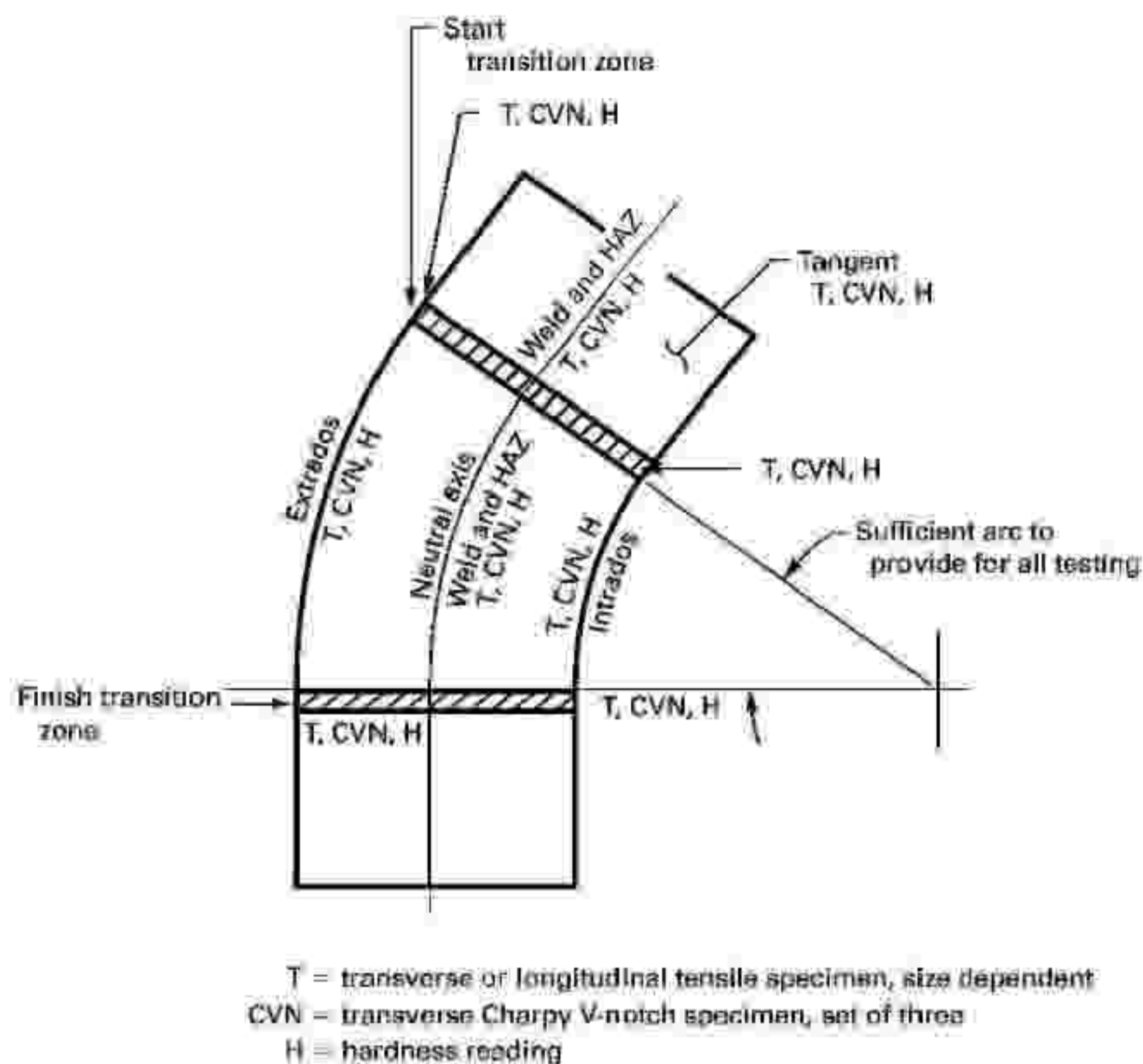

facilities shall be of sufficient size and shall be equipped to ensure proper and uniform cooling.

## 9.2 Equipment

All furnace heat-treatment equipment shall have a recording device that is calibrated at least quarterly. Heat-treat furnaces shall be surveyed annually, or at a shorter interval, as necessary to maintain uniformity of heat treatment, or thermocouples shall be attached to each furnace load. Thermocouples shall be calibrated at least quarterly. Records shall be kept of furnace surveys, thermocouple calibrations, and if used, thermocouple readings for each furnace load. The furnace shall be controlled within a range of  $\pm 15^{\circ}\text{C}$  ( $\pm 25^{\circ}\text{F}$ ).

## 9.3 Heat-Treat Designators

Each bend and the material test report (see section 14) shall be identified with one of the following designators indicating final heat-treat condition:

- N = normalize
- NT = normalize and temper
- SR = stress relieve
- QT = quench and temper

## 10 QUALIFICATION BEND

### 10.1 Essential Variables

Prior to production bending, a qualification bend shall be made and tested from each heat of material to demonstrate the suitability of the bending procedure to provide a product meeting the required dimensions and material properties. This bend and tangent section shall be of adequate length to obtain all the required test coupons. All bends (i.e., qualification and production) shall be completed in a continuous heating cycle without stops or starts, unless such areas are included in the bend procedure qualification testing and found acceptable. Postbend heating for production bend dimensional corrections is not allowed unless covered in the qualification bend procedure. The procedure qualification shall account for the essential variables required to make a bend. When any of these essential variables change, a new qualification bend must be made. The manufacturer's quality assurance program shall include procedures that ensure that the essential variables are properly controlled. This includes equipment calibration frequency as necessary for control but in no case less than annually. Essential variables are shown in Table 3.

## ASME B16.49-2017

Figure 3 Test Specimen Locations and Orientations — Helical Seam

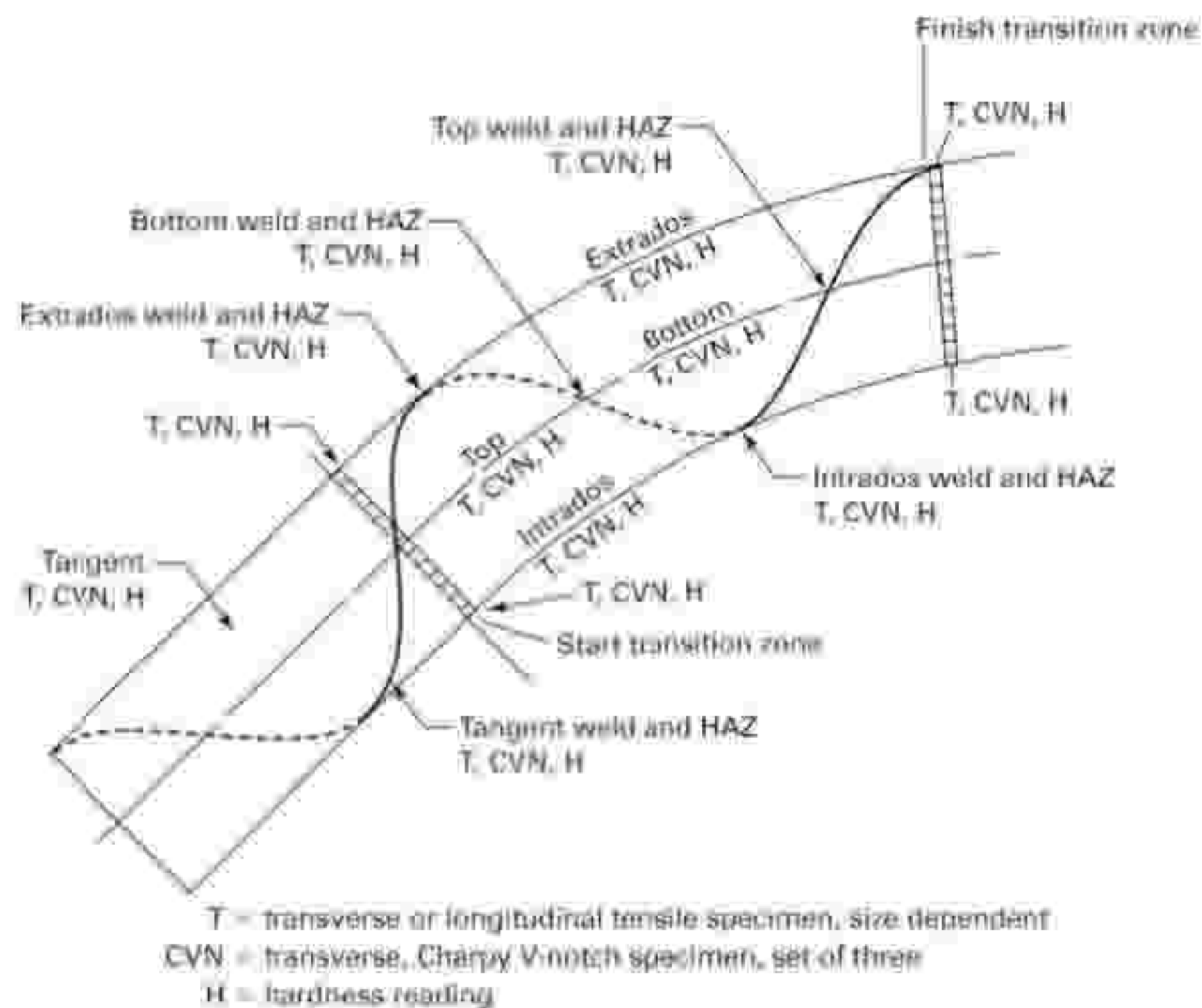

Table 3 Limits on Essential Variables

Essential Variable	Limits of Variation
Pipe wall thickness	$\pm 3$ mm (0.12 in.)
Bend-radius-to-diameter $+1R=0$ ratio ( $R/D_o$ )	
Forming velocity	$\pm 2.5$ mm (0.1 in.) per min
Forming temperature	$\pm 25^\circ\text{C}$ ( $\pm 50^\circ\text{F}$ ) from the qualification temperature
Coil design	No change allowed
Coolant type	No change allowed
Cooling water temperature	$\pm 15^\circ\text{C}$ ( $\pm 25^\circ\text{F}$ )
Flow rate/pressure of coolant	$\pm 10\%$ change in flow rate (or equivalent rate in pressure)
Weld seam	15 deg from the neutral axis
Heat treatment	$\pm 15^\circ\text{C}$ ( $\pm 25^\circ\text{F}$ ) in holding temperature or any change in procedure
Induction heating frequency	$\pm 20\%$
Soaking time	0 min to 15 min

## 10.2 Records

**10.2.1 Bend Qualification Procedure.** Each manufacturer shall prepare a written procedure that demonstrates that bends having suitable properties such as strength, ductility, and hardness can be formed by that procedure.

These records shall be available for the purchaser's review. Changes in the essential variables beyond the limits of variation shown in Table 3 shall require a new qualification bend test and procedure.

**10.2.2 Testing Results.** All applicable testing results shall be part of the records.

## 11 TEST REQUIREMENTS

The testing requirements differ between the qualification bend and the production bends. The following requirements apply in the locations specified. The qualification bend testing shall be conducted on a bend representative of the final heat-treat condition. The production bend tests shall be conducted on each bend in the same final heat-treat condition as that which produced the qualification bend.

### 11.1 Qualification Bend Requirements

**11.1.1 Tensile Testing.** Transverse tensile samples for NPS 8 (DN 200) or larger shall be taken from the tangent, the transition zone, and the bend segment at both the intrados and extrados for each lot of material as shown in Figure 2 or Figure 3. For sizes smaller than NPS 8 (DN 200), either transverse or longitudinal test specimens shall be used. If the tangents and/or transition

## ASME B16.49-2017

zones are not left integral to the bend, no tensile tests are required except on the bend. See [Figure 2](#) or [Figure 3](#).

**11.1.2 Fracture Toughness Testing.** A set of three transverse Charpy V-notch impact specimens shall be taken from the tangent, the transition zones, and the bend at both the intrados and extrados for each lot of material. See [Figure 2](#) or [Figure 3](#) for locations. If the tangents and/or transition zones are not left integral to the bend, no impact tests are required except on the bend. See [Figure 2](#) or [Figure 3](#).

### 11.1.3 Weld Testing

*(a) Longitudinal Seams.* The tensile, impact, and hardness tests shall be performed on the pipe or cylinder longitudinal seam weld at the locations shown in [Figure 2](#). Acceptance criteria shall be as specified in [paras. 8.1, 8.2, 8.3, and 11.1.4](#).

*(b) Helical Seam.* The tensile, impact, and hardness tests shall be performed on the pipe or cylinder helical seam at the locations shown in [Figure 3](#). Acceptance criteria shall be as specified in [paras. 8.1, 8.2, 8.3, and 11.1.4](#).

**11.1.4 Hardness Testing.** The bend shall be tested for average hardness in all the same locations as the tensile tests are taken as well as each transition zone. In addition, an average hardness reading shall be taken from a minimum of two locations in the bend at the extrados and intrados. The allowable difference between the minimum and maximum hardness readings for a quadrant around the circumference is 30 Brinell hardness number, or equivalent, if another testing method is used. See [Figure 2](#) or [Figure 3](#).

## 11.2 Production Bend Requirements

To demonstrate uniformity between the qualification and production bends, each production bend shall be hardness tested in all the same locations as the qualification bend. In addition, hardness readings shall be taken for each additional 30 deg of arc beyond the qualification bend angle. All values within like quadrants around the circumference shall be within the same range as determined in [para. 11.1.4](#). No readings shall exceed the maximum specified in [Table 1](#), and no average shall equate to a tensile strength less than the minimum required in [Table 1](#) for the specified grade.

## 11.3 Testing Results

The bend shall be marked with the appropriate grade symbol of [Table 1](#) based on the test results for all locations meeting the minimum values specified for that grade. If the bend strength is different from the mating pipe, and the substitution of wall thickness for yield strength is used in accordance with [para. 8.1](#), both the bend grade and the

intended mating pipe grade shall be marked on the bend (i.e., P414/X483).

## 12 DIMENSIONAL REQUIREMENTS

The dimensional requirements in [section 12](#) shall be met on each bend.

### 12.1 Ovality

Ovality shall be measured throughout the bend and tangents. The difference between the maximum and minimum outside diameter shall not exceed 3% of the nominal mating pipe outside diameter within the bend and 1% at the welding end. The purchaser and manufacturer may agree to a different ovality tolerance (see [para. SR15.3](#)).

### 12.2 Outside Diameter

The outside diameter of each welding end shall be within 1% of the nominal mating pipe outside diameter. The diameter throughout the bend and the remainder of the tangents need only meet the ovality tolerance, unless the purchaser and manufacturer agree to other tolerances.

### 12.3 Wall Thickness

The wall thickness shall be checked in sufficient locations throughout the bend to ensure that the minimum wall does not fall below 90% of the nominal mating wall thickness marked on the bend (or below the purchaser-specified minimum wall thickness). This below-tolerance allowance does not apply to those areas determined to need reinforcement as a result of design requirements of [para. 2.2](#). Inspection shall be done using compression wave ultrasonic examination by calibrated equipment that meets a procedure developed by the manufacturer to ensure accurate readings.

### 12.4 Inside Diameter

**12.4.1 Welding Ends.** For NPS 36 (DN 900) and smaller, the inside diameter tolerance at the bevel face shall be  $\pm 2.5$  mm ( $\pm 0.10$  in.). For larger sizes, the inside diameter tolerance shall be  $\pm 3$  mm ( $\pm 0.12$  in.).

**12.4.2 Body.** Unless otherwise agreed to by the purchaser, the average internal diameter at any location in the bend shall not be less than 97% of the minimum specified mating pipe internal diameter. Proof of conformance to this requirement shall be demonstrated by passing a sphere or other suitable gaging device through the bend without assistance of power equipment.

### 12.5 End Preparation

Welding ends shall be beveled using ASME B16.25, [Figure 2](#) illustration (a) or [Figure 3](#) illustration (a) end preparations, unless otherwise specified by the purchaser.

## ASME B16.49-2017

**12.6 Bend Dimensional Tolerances**

The bend angle, center-to-end dimensions, bend radius, chord lengths, squareness, and bend plane shall be measured and recorded for each bend. The tolerances on the ordered dimensions shall be as follows:

Dimension	Tolerance
Bend angle	$\pm 1/2$ deg
Bend radius	$\pm 1\%$
Bend plane	$\pm 1$ deg
End squareness	
NPS 36 (DN 900) and smaller	$\pm 2.4$ mm (0.09 in.)
Greater than NPS 36 (DN 900)	$\pm 3$ mm (0.12 in.)
Linear dimensions	
NPS 24 (DN 600) and smaller	$\pm 5$ mm (0.19 in.)
Greater than NPS 24 (DN 600)	$\pm 6$ mm (0.25 in.)

See Figure 4, illustrations (a) and (b).

**13 INSPECTION OF PRODUCTION BENDS****13.1 Workmanship and Finish**

If required for inspection, all bends shall be grit-blasted or shot-blasted clean to a bright metal finish in accordance with SSPC-SP 6. All bends shall be visually examined on all accessible surfaces for laminations, cracks, notches, gouges, arc burns, wrinkles, or other defects. Surface imperfections shall be removed by grinding or machining, provided they are not deeper than allowed in para. 12.3. Repair by welding of base metal or weld metal is not permitted without purchaser approval. It is characteristic of the induction process that an upset occurs at each tangent point (transition) of a bend. These are of a cosmetic nature and are not classified as injurious defects, provided these upsets have a dimension measured from peak to valley not exceeding 2% of the pipe outside diameter.

**13.2 Nondestructive Examination**

The entire extrados of each bend, from neutral axis to neutral axis including the weld seam, shall be a magnetic particle or liquid penetrant examined for injurious defects. The area shall be free of cracks, laps, or laminations. All rounded indications greater than 3 mm (0.12 in.) in any direction shall be classified as imperfections and shall be removed as required in para. 13.1.

**13.3 Outside Inspection**

An inspector representing the purchaser shall be authorized access to areas of the manufacturer's facility that involve the manufacture of the ordered bends. All testing records, welding records, etc., shall be available for inspection prior to shipment.

**14 CERTIFICATION**

A Certified Material Test Report (CMTR) shall be furnished listing as a minimum the following information:

- (a) chemical composition (including CE)
- (b) tensile properties
- (c) impact properties
- (d) hardness results
- (e) heat treatment
- (f) bend qualification procedure
- (g) welded or seamless
- (h) nondestructive examination results
- (i) applicable supplementary requirements (paras. SR15.1 through SR15.8)

**SR15 SUPPLEMENTARY REQUIREMENTS**

The supplementary requirements (paras. SR15.1 through SR15.8) are not applicable to the product furnished to this Standard except when specified on the purchase order or otherwise agreed upon. When specified or agreed upon, supplementary requirements shall have the same force as requirements of mandatory sections 1 through 14. Each bend shall be marked with the applicable supplementary requirement (e.g., SR15.1) after the normal marking required in para. 4.1.

**SR15.1 Heat Treatment**

Bends can be furnished in an "as-bent" condition. The properties of section 8 must be met for that heat of material offered. Each bend shall be identified with AB SR15.1 as the heat-treat designator.

**SR15.2 Nondestructive Examination**

Magnetic particle or liquid penetrant examination shall be performed on the bend area including the intrados, extrados, and weld seam. No cracks are permitted. All other indications will be addressed by an agreement between the purchaser and manufacturer. All inspections shall be done by personnel and procedures approved by the purchaser.

**SR15.3 Segmentable Bends**

Bends required to be suitable for segmentation shall be provided with an ovality through the bend and tangents of 1% maximum.

**SR15.4 Fracture Toughness**

Notch toughness requirements other than those specified shall be by agreement between the purchaser and manufacturer. This can include lower test temperatures, greater-absorbed energy requirements, or different shear area requirements.

ASME B16.49-2017

Figure 4 Measurement of Bend Angle and Out-of-Squareness

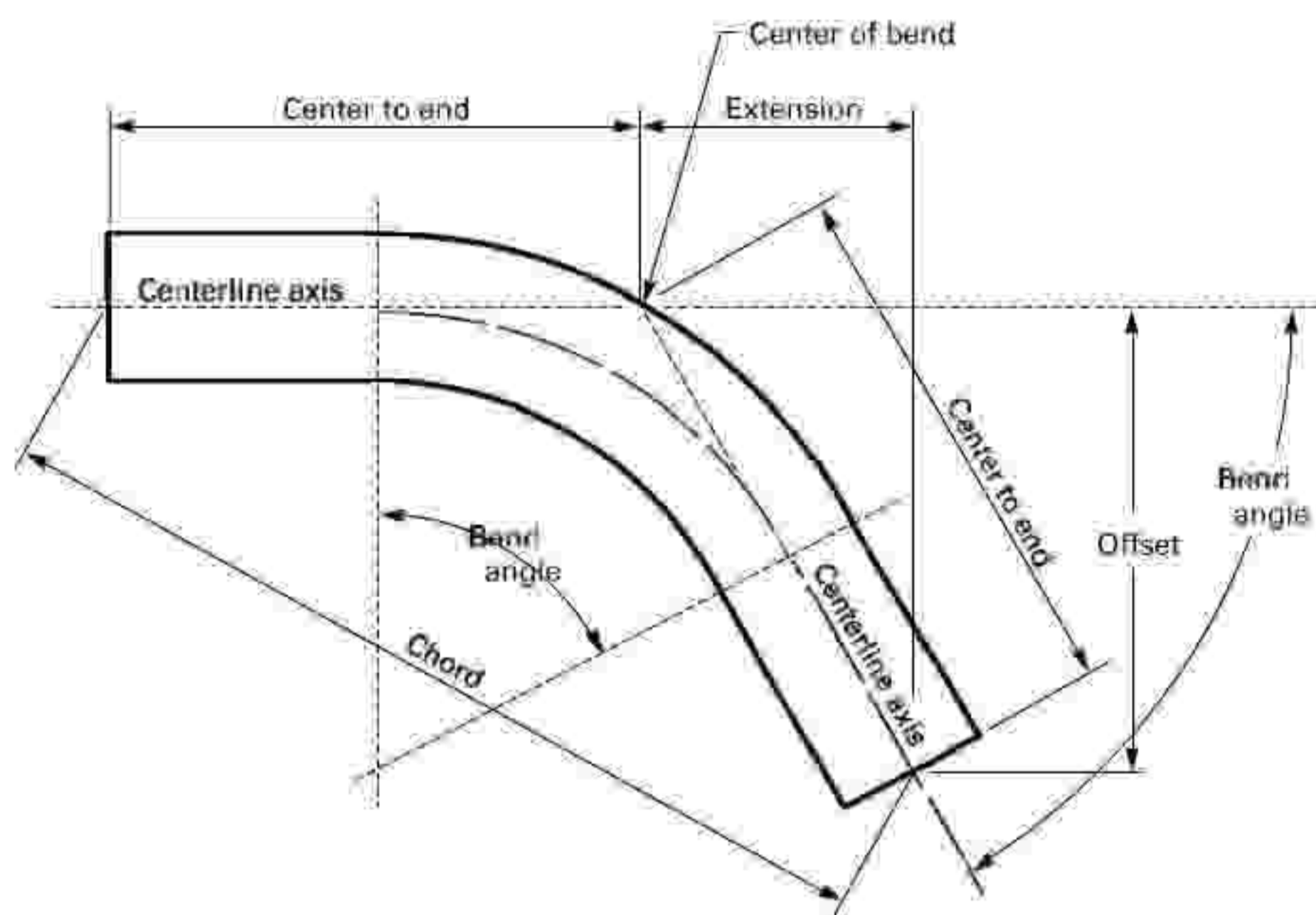

(a) Measurement of Bend Angle by Measurement and Calculation

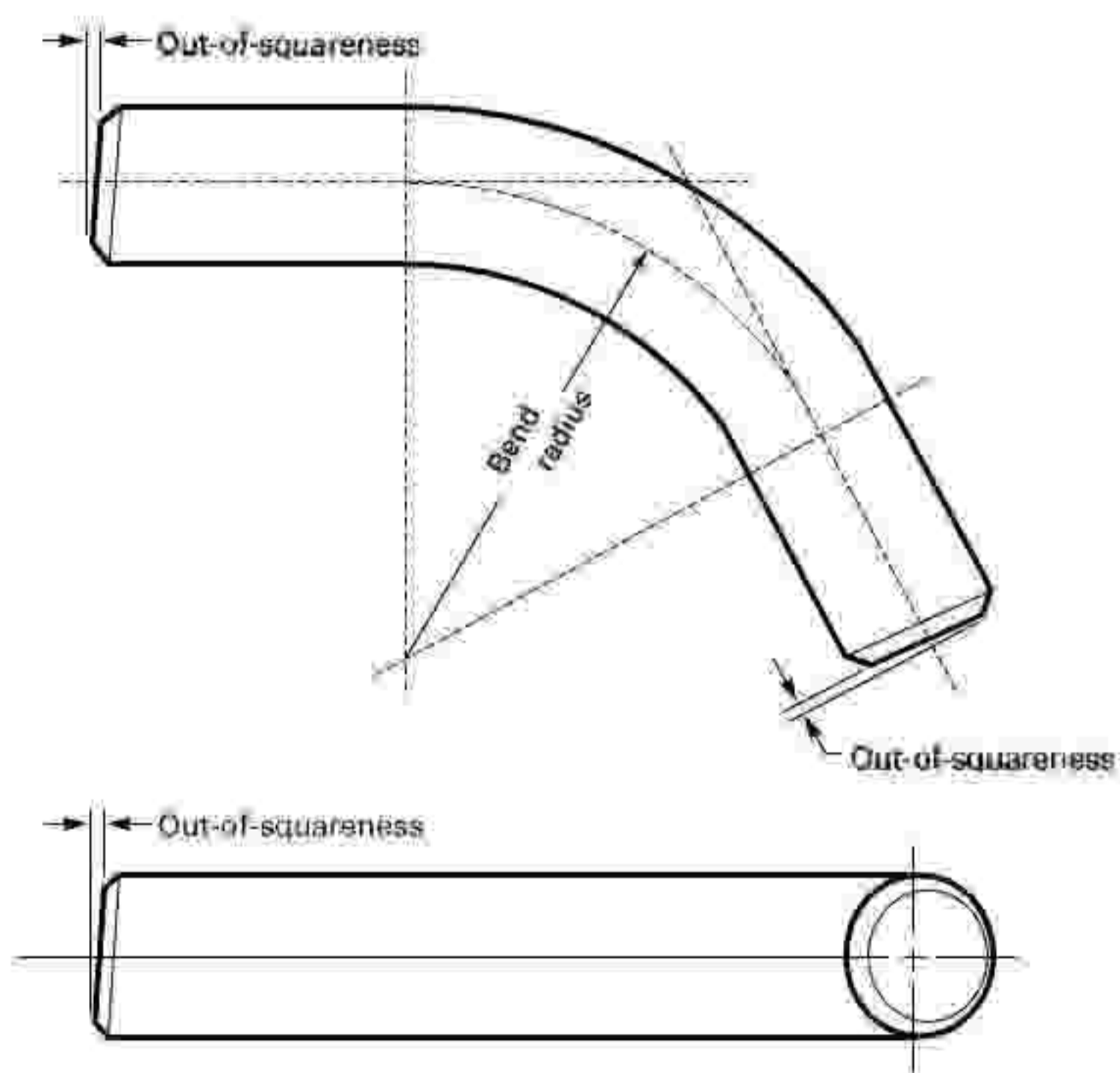

(b) Measurement of Out-of-Squareness

## ASME B16.49-2017

**SR15.5 Sour Gas Applications**

Bends required for sour gas applications shall be furnished to meet ANSI/NACE MR0175/ISO 15156.

**SR15.6 Weld Seam Examination: UT**

**SR15.6.1** In lieu of radiography, each weld seam in a pipe or starting cylinder may be ultrasonically tested. Acceptance criteria shall be by agreement between the purchaser and manufacturer.

**SR15.6.2** Each bend shall be ultrasonically examined for the full length of weld from bevel end to bevel end after forming and final heat treatment. Testing procedure and acceptance standards shall be as agreed upon between the purchaser and manufacturer.

**SR15.7 Weld Seam Examination: RT**

Each bend shall have the weld seam 100% radiographed for the full length from bevel end to bevel end after forming and final heat treatment. Testing procedure and acceptance standards shall be as agreed upon between the purchaser and manufacturer.

**SR15.8 Chemistries**

**SR15.8.1** Alternative chemical requirements and/or lower carbon equivalent shall be as agreed to by the purchaser and manufacturer.

**SR15.8.2** Acceptance of previous bend qualification procedures based on similar material chemistries shall be as agreed upon between the purchaser and manufacturer. This can include variations to other essential variable requirements if agreed upon.

## MANDATORY APPENDIX I REFERENCES

017P

The following is a list of publications referenced in this Standard. Unless otherwise specified, the latest edition of ASME publications shall apply.

- ANSI/NACE MR0175/ISO 15156:2015, Petroleum and natural gas industries — Materials for use in H<sub>2</sub>S-containing environments in oil and gas production  
 Publisher: National Association of Corrosion Engineers (NACE International), 15835 Park Ten Place, Houston, TX 77084-4906 ([www.nace.org](http://www.nace.org))
- ASME Boiler and Pressure Vessel Code  
 ASME B16.25, Buttwelding Ends  
 ASME B31 Code for Pressure Piping  
 ASME B36.10M, Welded and Seamless Wrought Steel Pipe  
 Publisher: The American Society of Mechanical Engineers (ASME), Two Park Avenue, New York, NY 10016-5990 ([www.asme.org](http://www.asme.org))
- ASTM A370-15, Standard Test Methods and Definitions for Mechanical Testing of Steel Products  
 ASTM E29-13, Practice for Using Significant Digits in Test Data to Determine Conformance With Specifications  
 ASTM E140-12be1, Hardness Conversion Table for Metals  
 Publisher: The American Society for Testing and Materials (ASTM International), 100 Barr Harbor Drive, P.O. Box C700, West Conshohocken, PA 19428-2959 ([www.astm.org](http://www.astm.org))
- ISO 6708:1995, Pipework components — Definition and selection of DN (nominal size)  
 ISO 9000:2015, Quality management systems — Fundamentals and vocabulary  
 ISO 9001:2015, Quality management systems — Requirements  
 ISO 9004:2009, Managing for the sustained success of an organization — A quality management approach  
 Publisher: International Organization for Standardization (ISO), Central Secretariat, Chemin de Blandonnet 8, Case Postale 401, 1214 Vernier, Geneva, Switzerland ([www.iso.org](http://www.iso.org))
- SSPC-SP 6/NACE No. 3, Commercial Blast Cleaning  
 Publisher: The Society for Protective Coatings (SSPC), 800 Trumbull Drive, Pittsburgh, PA 15205 ([www.sspc.org](http://www.sspc.org))



## NONMANDATORY APPENDIX A QUALITY SYSTEM PROGRAM

The products manufactured in accordance with this Standard shall be produced under a quality system program following the principles of an appropriate standard from the ISO 9000 series.<sup>1</sup> A determination of the need for registration and/or certification of the product manufacturer's quality system program by an independent organization shall be the responsibility of the manufacturer. Detailed documentation demonstrating

program compliance shall be available to the purchaser at the manufacturer's facility. A written summary description of the program utilized by the product manufacturer shall be available to the purchaser upon request. The product manufacturer is defined as the entity whose name or trademark appears on the product in accordance with the marking or identification requirements of this Standard.

<sup>1</sup>The series is also available from the American National Standards Institute (ANSI) and the American Society for Quality (ASQ) as American National Standards that are identified by the prefix "Q," replacing the prefix "ISO." Each standard of the series is listed under References in Mandatory Appendix I.

ASME B16.49-2017

## NONMANDATORY APPENDIX B INDUCTION BEND DATA SHEET

### Induction Bend Data Sheet

SO# _____	Quote Order # _____	Project Ref: _____
Specification _____	ASME B16.49 latest edition Specification: latest edition as minimum	
<b>Bend Procedure Qualification Test is Required for Each Representative Heat of Pipe.</b>		
Design Conditions		
Bend Size _____	Weld _____	Grade _____
Radius: _____ DN (nominal diameter)		
Bend Angle _____	Tangent Length: _____	
	One End <input type="checkbox"/>	Both <input type="checkbox"/>
Minimum CL Length Required Between Bends: _____		
Field Segmentable Bend: <input type="checkbox"/> Yes <input type="checkbox"/> No		
Coating Required: <input type="checkbox"/> Yes <input type="checkbox"/> No		
Min. I.D. at Ends and in Body: _____		
<small>NOTE: Vendor to supply pipe to meet the above design conditions and be sized at the ends to meet the following:</small> <small>(a) The ends of each bend line to be finished to match the pipe to which it is to be welded (see Appendix I, Fig. I-3 of ASME B31.8, Gas Transmission and Distribution Piping Systems, for bend detail for tangent weld fit-up).</small> <small>(b) The allowable welding mismatch tolerance is 0.047 in. for walls up to 0.250 in. and 0.094 in. for walls 0.251 in. and greater.</small>		
Toughness Properties Acceptance Criteria: _____		
Temperature of Charpy Testing: _____		

# ASME B16.49-2017

ISBN 978-0-7918-7185-0



9 780791 871850



B16.49-2017